

Rev.	Description	Initiator	Date
04	ECO 13994; Added Note 8	SZJ	5/23/2016

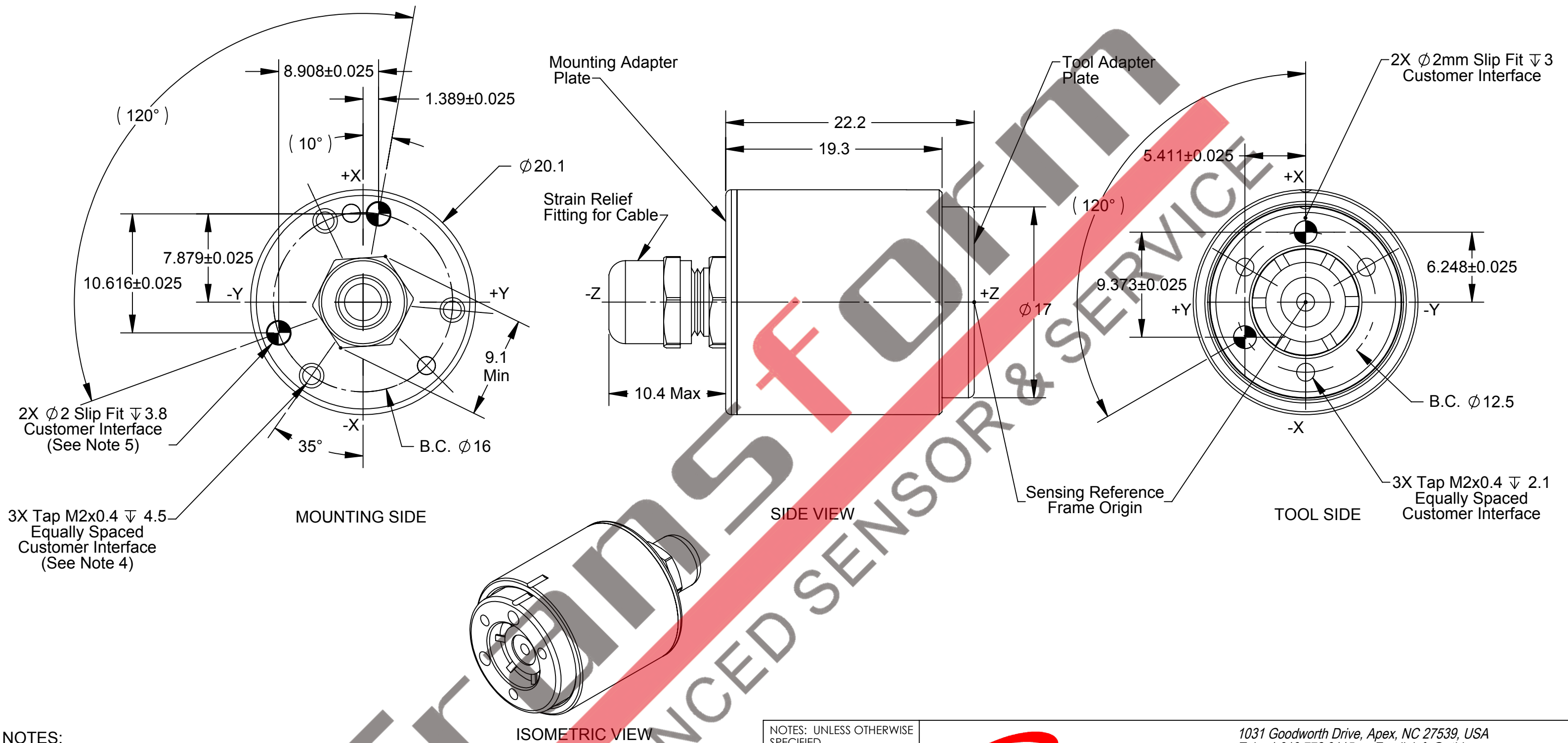

- NOTES:**
1. Material: Stainless Steel
 2. Tool and Mounting Adapters have M2 tapped holes and 2mm dowel pin holes for interfacing
 3. **WARNING: DO NOT LOOSEN OR REMOVE INTERFACE PLATES DUE TO POTENTIAL DAMAGE**
 4. No threads present first 1mm of interface
 5. No dowel interface first 1mm of interface
 6. Standard connector (not shown) has 17mm diameter & is 67.5mm long.
 7. Cable is IP65/IP68 rated only at transducer end.
 8. Alignment marks are for ATI reference only.

NOTES: UNLESS OTHERWISE SPECIFIED.
DO NOT SCALE DRAWING. ALL DIMENSIONS ARE IN MILLIMETERS.

3rd ANGLE PROJECTION

1031 Goodworth Drive, Apex, NC 27539, USA
 Tel: +1.919.772.0115 Email: info@ati-ia.com
 Fax: +1.919.772.8259 www.ati-ia.com
 ISO 9001 Registered Company

PROPERTY OF ATI INDUSTRIAL AUTOMATION, INC. NOT TO BE REPRODUCED IN ANY MANNER EXCEPT ON ORDER OR WITH PRIOR WRITTEN AUTHORIZATION OF ATI.

DRAWN BY: C. Sturgis 1/11/10		TITLE	
CHECKED BY: R. Chambers 1/12/10		IP65/68 Nano17 Transducer w/ Axial Cable Exit	
PROJECT #	SHEET 1 OF 1	SCALE	REVISION
		3:1	04
		SIZE	DRAWING NUMBER
		B	9230-05-1364